



Guide de pose des radiateurs - Plaatsingswijze van de radiatoren Fitting instructions - Istruzioni per l'installazione dei radiatori Guia de instalacion de radiadores - Befestigungshinweise heizkörper

Z21680 09/10

Purgeur à jet orientable

Serrez modérément le purgeur sur le radiateur pour faire étanchéité à l'aide du joint torique. Desserrez le pointeau et tournez le cône pour diriger le jet comme vous le souhaitez.

Oriënteerbare ontluchter

De ontluucher met mate op de radiator aanschroeven zodanig dat met de rubberen dichtingsring een hechte dichting bekomen wordt. Om te ontluuchen, de puntschroef enigszins losschroeven en het conisch gedeelte verdraaien om de waterstraal in de gewenste richting te kunnen opvangen.

Swivelling air bleed valve

Tighten the bleed valve moderately on the radiator with the o-ring to ensure watertightness. Loosen the needle valve and turn the cone to direct the jet in the required direction.

This steel radiator is suitable for connection to the central heating system only. When new or additional radiators are being installed, the system should be drained, cleaned and flushed in accordance with BS7593 and a good quality inhibitor, suitable for mixed metal system, used to protect the system.

If in doubt, seek professional advice.

(For information on water treatment, please call the Water Treatment helpline on 01799 521133).

Rubinetto di sfiato a getto orientabile.

Serrare moderatamente il rubinetto di sfiato situato sul radiatore per ottenere la tenuta mediante O-ring. Allentare il comando di apertura del rubinetto di sfiato e ruotare il cono per orientare il getto come desiderate.

Purgador de chorro orientable.

Apriete con moderación el purgador en el radiador para obtener la hermeticidad por medio de la junta tórica. Afloje la aguja de punta cónica y gire el cono para dirigir el chorro en la dirección que desee.

Entlüftung mit dirigierbarem Wasserstrahl

Schrauben Sie die Entlüftung auf dem Heizkörper fest, so daß der Dichtungsring die Dichtigkeit gewährleistet. Lösen Sie die seitliche Entlüftungsschraube und drehen Sie die Entlüftungskanüle in die gewünschte Richtung.

HK-HKD

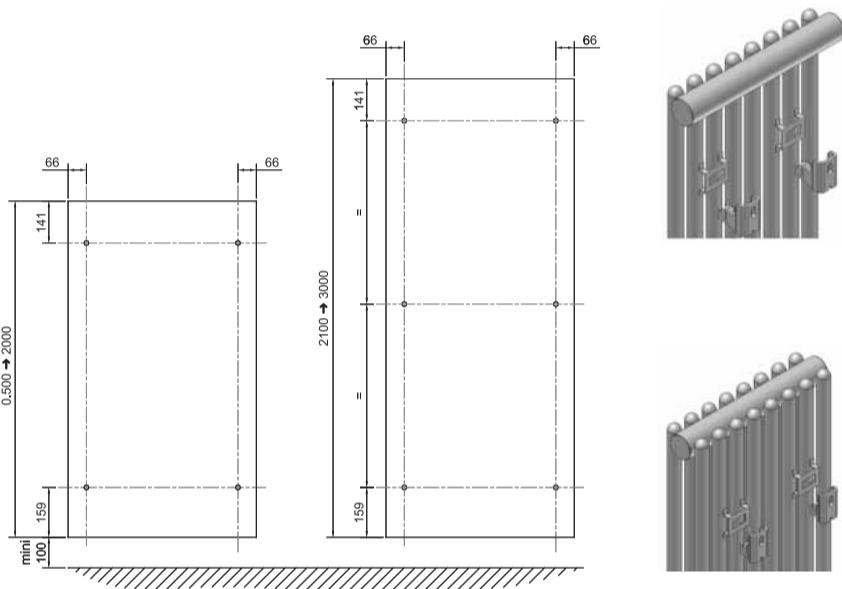

VK-VKD

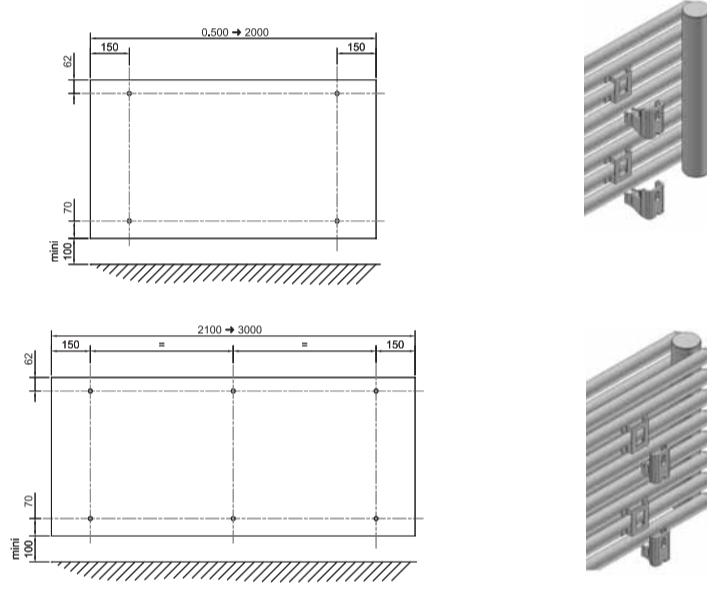

KLV - KXH KLVD - KXHD

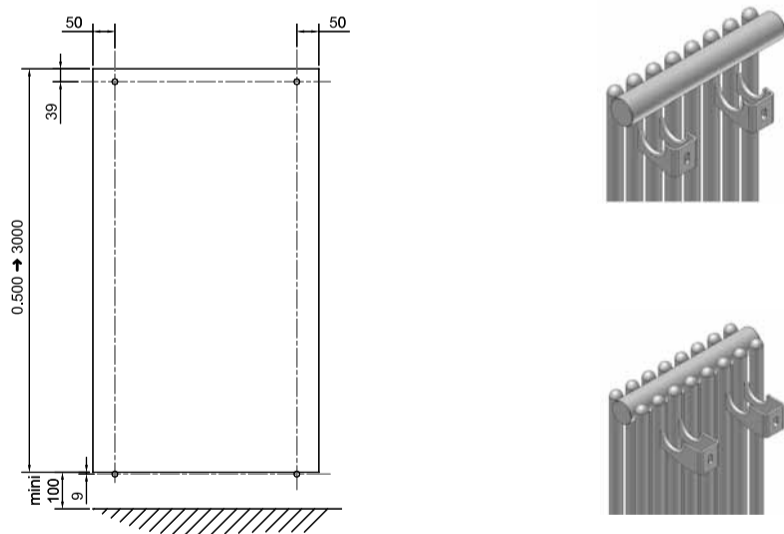

KLH - KXV KLHD - KXVD

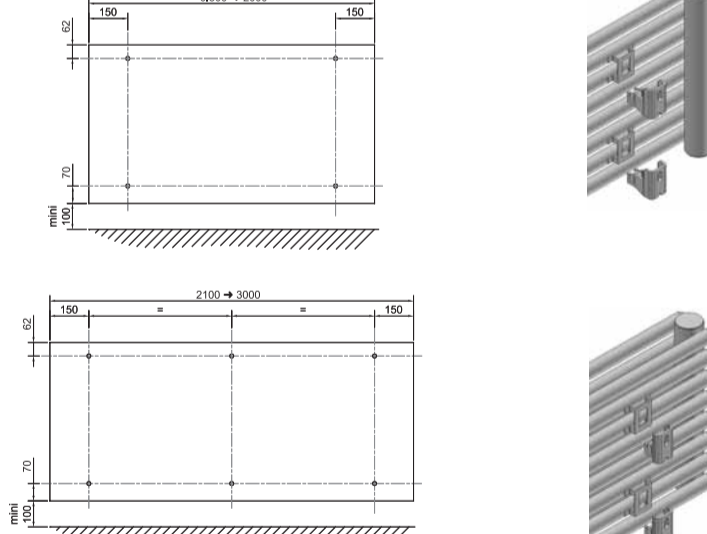

Fixations pour murs creux et friables
Bevestigingen voor holle en brokkelige muren
Fixing for hollow and friable walls
Attachi per muri cavi e friabili
Fijaciones para muros huecos y fragiles
Befestigungen für hohle und brüchige wände

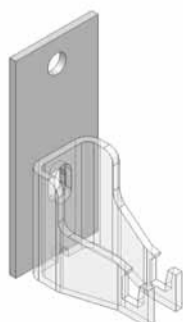



Z21680 09/10

Guide de pose des radiateurs - Plaatsingswijze van de radiatoren Fitting instructions - Istruzioni per l'installazione dei radiatori Guia de instalacion de radiadores - Befestigungshinweise Heizkörper

Purgeur à jet orientable

Serrez modérément le purgeur sur le radiateur pour faire étanchéité à l'aide du joint torique. Desserrez le pointeau et tournez le cône pour diriger le jet comme vous le souhaitez.

Oriënteerbare ontluchter

De ontlufter met mate op de radiator aanschroeven zodanig dat met de rubberen dichtingsring een hechte dichting bekomen wordt. Om te ontluften, de puntschroef enigszins losschroeven en het conisch gedeelte verdraaien om de waterstraal in de gewenste richting te kunnen opvangen.

Swivelling air bleed valve

Tighten the bleed valve moderately on the radiator with the o-ring to ensure watertightness. Loosen the needle valve and turn the cone to direct the jet in the required direction.

This steel radiator is suitable for connection to the central heating system only. When new or additional radiators are being installed, the system should be drained, cleaned and flushed in accordance with BS7593 and a good quality inhibitor, suitable for mixed metal system, used to protect the system.

If in doubt, seek professional advice.

(For information on water treatment, please call the Water Treatment helpline on 01799 521133).

Rubinetto di sfiato a getto orientabile.

Serrare moderatamente il rubinetto di sfiato situato sul radiatore per ottenere la tenuta mediante O-ring. Allentare il comando di apertura del rubinetto di sfiato e ruotare il cono per orientare il getto come desiderate.

Purgador de chorro orientable.

Apriete con moderación el purgador en el radiador para obtener la hermeticidad por medio de la junta tórica. Afloje la aguja de punta cónica y gire el cono para dirigir el chorro en la dirección que desee.

Entlüftung mit dirigierbarem Wasserstrahl

Schrauben Sie die Entlüftung auf dem Heizkörper fest, so daß des Dichtungsring die Dichtigkeit gewährleistet. Lösen Sie die seitliche Entlüftungsschraube und drehen Sie die Entlüftungskanüle in die gewünschte Richtung.

HY - HYD

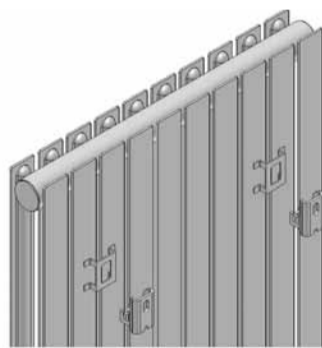
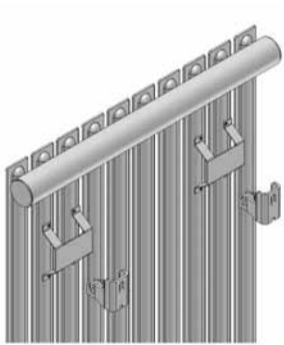
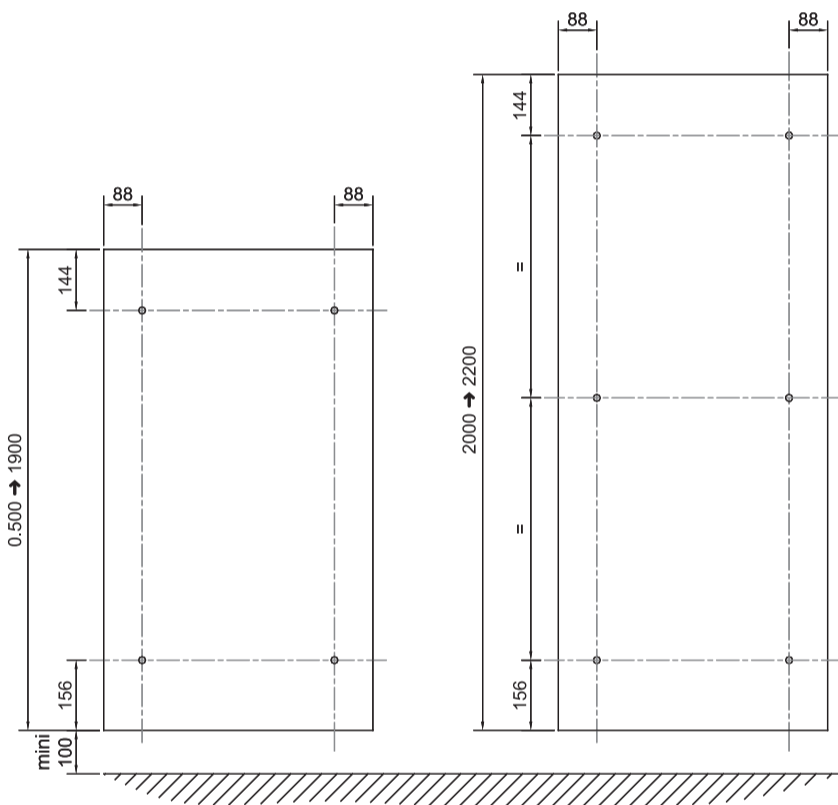

VY

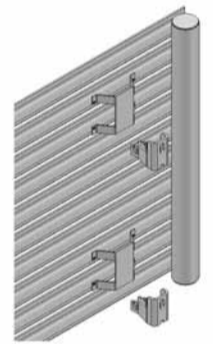
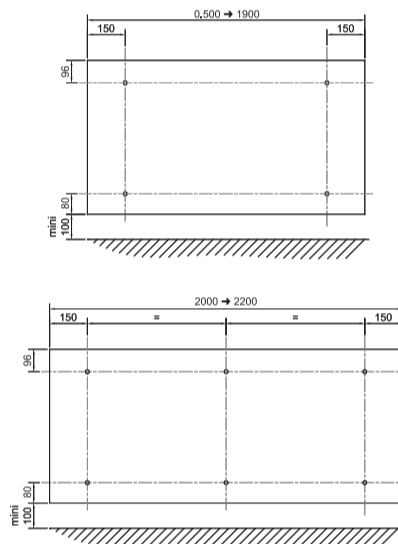

VYD

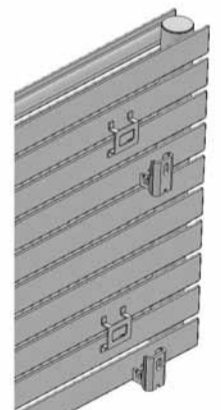
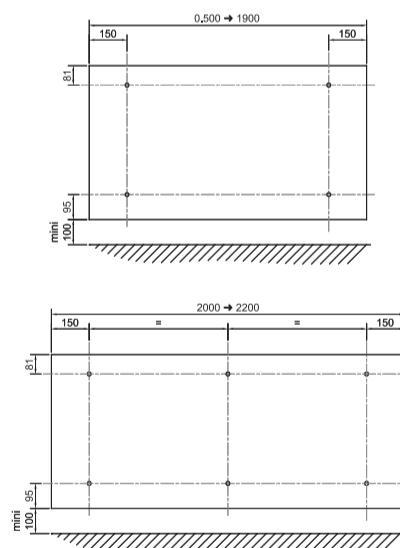

Fixations pour murs creux et friables
Bevestigingen voor holle en brokkelige muren
Fixing for hollow and friable walls
Attachi per muri cavi e friabili
Fijaciones para muros huecos y fragiles
Befestigungen für hohle und brüchige wände

